



## 20 MIN. POSITIVE PRESSURE FIRE DOOR INSTALLATIONS

---

### WH = PP CAT A

1. Doors must be installed in a *Listed and Labeled* Minimum 22 gauge K-D or welded steel frame, or *fire-rated* aluminum frame, or *fire-rated* wood frames.
2. This door assembly does NOT require the installation of surface fire-rated seal system.
3. Trimming for height may be done only on the bottom rail (per NFPA 80, maximum trim of  $\frac{3}{4}$ " [19.0mm] allowed on site).
4. Surface-mounted hardware must be attached with through-bolts unless interior blocking is provided.
5. A maximum of  $\frac{1}{8}$ " (3.2mm) clearance between the frame and door (or leaves of pair) is allowed.
6. For Flush Bolts a strip of 1 inch wide Tecnofire 2000 or two strips of Pemko HSS2000 shall be applied across the top of the flush bolt.
7. Doors with light cutouts install a light kit listed and labeled for compliance with UBC 7-2-97 for specific type of door. Install kit per manufacturer's instructions.
8. If door assembly requires "S" rating for smoke rating, a *fire-rated* smoke and draft control gasket shall be installed to the opening. The smoke and draft control gasket shall be labeled showing compliance with UBC 7-2-97, Parts I & II. Smoke gaskets are to be installed per instructions provided with the gasket system and must be compatible with the door and frame type.



## 20 MIN. POSITIVE PRESSURE FIRE DOOR INSTALLATIONS

---

### WH = PP CAT B

1. Doors must be installed in a *Listed and Labeled* Minimum 22 gauge K-D or welded steel frame, or *fire-rated* aluminum frame, or *fire-rated* wood frames.
2. Perimeter of opening **MUST** be furnished with a “listed” surface *fire-rated* edge seal system. Follow specific manufacturer’s instructions for proper installation.  
  
Pemko HSS 2000 around perimeter - OR -  
Any other manufacturers Hot Smoke seal that meets the requirements of UBC 7-2, Part I, Positive Pressure.
3. Trimming for height may be done only on the bottom rail (per NFPA 80, maximum trim of ¾” [19.0mm] allowed on site).
4. Surface-mounted hardware must be attached with through-bolts unless interior blocking is provided.
5. A maximum of 1/8” (3.2mm) clearance between the frame and door (or leaves of pair) is allowed.
6. For Flush Bolts a strip of 1 inch wide Tecnofire 2000 or two strips of Pemko HSS2000 shall be applied across the top of the flush bolt
7. Doors with light cutouts install a light kit listed and labeled for compliance with UBC 7-2-97 for specific type of door. Install kit per manufacturer’s instructions.
8. If door assembly requires “S” rating for smoke rating, a *fire-rated* smoke and draft control gasket shall be installed to the opening. The smoke and draft control gasket shall be labeled showing compliance with UBC 7-2-97, Parts I & II. Smoke gaskets are to be installed per instructions provided with the gasket system and must be compatible with the door and frame type.



## INSTALLATION INSTRUCTIONS FOR 20-MINUTE POSITIVE PRESSURE AND SMOKE CONTROL DOORS

---

To meet positive pressure and smoke control requirements per UBC 7-2-97, Parts I & II, doors must be installed with fire-rated smoke and draft control gasketing. In some cases, an intumescent seal may be required, as noted below. The smoke and draft control gasket shall be “Listed” for compliance with test procedure UBC Standard 7-2-97, Parts I & II. Refer to gasketing manufacturer’s installation instructions for frame preparation and application guidelines, unless otherwise specified below.

- Category “H” 20 minute Positive Pressure single swing doors (4-0 x 9-0 max.)
  - 1) Install “Listed” Pemko S88 or S44 smoke gasketing at both jamb legs and header (See drawing E). This category includes gasket systems that are surface-applied (such as kerf-applied, adhesive-backed, or mechanically attached) to frames or doors.
  - 2) Any other manufacturers smoke and draft control gasket that meets the requirements of UBC 7-2, Part I & II, Positive Pressure, and has been tested to meet the applicable size requirements may be used.
  - 3) Must be installed in a *Listed and Labeled* minimum 22 gauge K-D or welded steel frame (masonry or drywall) or aluminum frame with a minimum throat depth of 4” – OR – a wood frame with a minimum wall thickness of 3-3/4”.
  - 4) This application meets the requirements of Positive Pressure and is eligible to receive the “S” mark on the fire-rating label.
  
- Category “H” 20 minute Positive Pressure paired doors (8-0 x 9-0 max.)
  - 1) Install “Listed” Pemko S88 or S44 smoke gasketing at both jamb legs and header (See drawing E). This category includes gasket systems that are surface-applied (such as kerf-applied, adhesive-backed, or mechanically attached) to frames or doors.
  - 2) Install Pemko S77 smoke gasket at the meeting edge of one door. (HSS 1000 is factory installed in the meeting edge with a veneer applied over the intumescent). (See drawing D).
  - 3) Any other manufacturers smoke and draft control gasket that meets the requirements of UBC 7-2, Part I & II, Positive Pressure, and has been tested to meet the applicable size requirements may be used.



- 4) Must be installed in a *Listed and Labeled* minimum 22 gauge K-D or welded steel frame (masonry or drywall) or aluminum frame with a minimum throat depth of 4" – OR – a wood frame with a minimum wall thickness of 3-3/4".
  - 5) This application meets the requirements of Positive Pressure and is eligible to receive the "S" mark on the fire-rating label.
- Category "B" 20 minute Positive Pressure single swing doors (4-0 x 9-0 max.) – Including door and transom assemblies with a transom bar.
- 1) Install "Listed" Pemko S-88 gasketing next to the stop and apply Pemko HSS 2000 intumescent hot smoke seal 5/8" from the stop on both jamb legs and header (see drawing B).
    - \* \*Any manufacturers smoke and draft control gasket and hot smoke seal that meets the requirements of UBC 7-2, Part I & II, Positive Pressure, and has been tested to meet the applicable size requirements may be used.
    - \* \*These systems are surface-applied to either the perimeter of the door or frame. They may be kerf-applied, adhesive-backed, or mechanically fastened.
  - 2) Must be installed in a *Listed and Labeled* minimum 22 gauge K-D or welded steel frame (masonry or drywall) or aluminum frame with a minimum throat depth of 4" – OR – a wood frame with a minimum wall thickness of 3-3/4".
  - 3) For door and transom assemblies *with* a transom bar, use the same installation method as the door and apply both seals on all edges of the frame.
- Category "B" 20 minute Positive Pressure paired doors (8-0 x 9-0 max.) (With FMEA Edge Guards) – Including door and transom assemblies with a transom bar.
- 1) Install "Listed" Pemko S-88 gasketing next to the stop and apply Pemko HSS 2000 intumescent hot smoke seal 5/8" from the stop on both jamb legs and header. (see drawing B).
    - \* Any manufacturers smoke and draft control gasket and hot smoke seal that meets the requirements of UBC 7-2, Part I & II, Positive Pressure, and has been tested to meet the applicable size requirements may be used.
    - \* These systems are surface-applied to either the perimeter of the door or frame. They may be kerf-applied, adhesive-backed, or mechanically fastened.
    - \* After installing the metal edge and astragal on the doors, apply Pemko HSS 2000 intumescent hot smoke seal on one leaf of the pair at the meeting edge (See drawing C).



- 2) Must be installed in a *Listed and Labeled* minimum 22 gauge K-D or welded steel frame (masonry or drywall) or aluminum frame with a minimum throat depth of 4" – OR – a wood frame with a minimum wall thickness of 3-3/4".
  - 3) For door and transom assemblies *with* a transom bar, use the same installation method as the door and apply both seals on all edges of the frame.
- Category "B" 20 minute Positive Pressure paired doors (8-0 x 9-0 max.) (Without Metal Edge Guards) – Including door and transom assemblies with a transom bar.
- 1) Install "Listed" Pemko S-88 gasketing next to the stop and apply Pemko HSS 2000 intumescent hot smoke seal 5/8" from the stop on both jamb legs and header. (see drawing B).
    - \* Any manufacturers smoke and draft control gasket and hot smoke seal that meets the requirements of UBC 7-2, Part I & II, Positive Pressure, and has been tested to meet the applicable size requirements may be used.
    - \* These systems are surface-applied to either the perimeter of the door or frame. They may be kerf-applied, adhesive-backed, or mechanically fastened.
    - \* The meeting edge intumescent seal system is part of the door construction. Apply a strip of Pemko S77 smoke seal gasket centered on top of the intumescent, on one leaf of the pair at the meeting edge (See drawing D).
  - 2) Must be installed in a *Listed and Labeled* minimum 22 gauge K-D or welded steel frame (masonry or drywall) or aluminum frame with a minimum throat depth of 4" – OR – a wood frame with a minimum wall thickness of 3-3/4".
  - 3) For door and transom assemblies *with* a transom bar, use the same installation method as the door and apply both seals on all edges of the frame.



**Note:** Drawings on this page pertain to 20 minute rated doors.

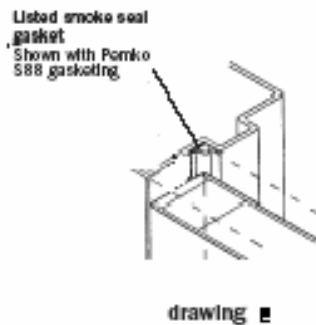
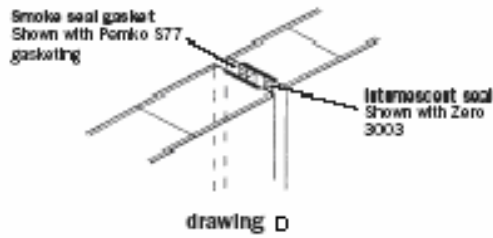
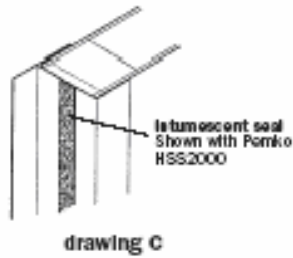
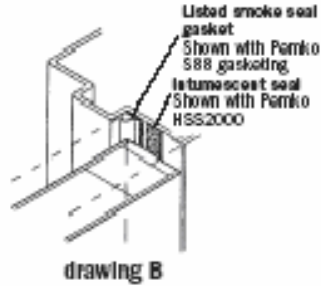

Meets CAT. "H" Requirements  
For positive pressure label.

**45/60/90 MIN**

**POSITIVE**



## PRESSURE FIRE DOOR INSTALLATIONS

---

**WH = 45 PP CAT A**

**WH = 60 PP CAT A**

**WH = 90 PP CAT A**

1. Doors must be installed in a *Listed and Labeled* steel frame – 16 or 18 gauge – OR – a *Listed and Labeled* kerf type steel frame – minimum 16 gauge.
2. This door assembly does **NOT** require the installation of surface *fire-rated* seal system. **DO NOT** install any additional edge seal system to this assembly. The seal system is part of the door construction.
3. Trimming for height may be done only on the bottom rail (per NFPA 80, maximum trim of ¾" [19.0mm] allowed on site).
4. Surface-mounted hardware must be attached with through-bolts unless interior blocking is provided.
5. A maximum of 1/8" (3.2mm) clearance between the frame and door (or leaves of pair) is allowed.
6. Doors with light cutouts install a light kit listed and labeled for compliance with UBC 7-2-97 for specific type of door. Install kit per manufacturer's instructions.
7. If door assembly requires "S" rating for smoke rating, a *fire-rated* smoke and draft control gasket shall be installed to the opening. The smoke and draft control gasket shall be labeled showing compliance with UBC 7-2-97, Parts I & II. Smoke gaskets are to be installed per instructions provided with the gasket system and must be compatible with the door and frame type.



## 45/60/90 MIN. POSITIVE PRESSURE FIRE DOOR INSTALLATIONS

---

**WH = 45PP CAT-B**

**WH = 60PP CAT-B**

**WH = 90PP CAT-B**

1. Doors must be installed in a *Listed and Labeled* steel frame – 16 or 18 gauge – OR – a *Listed and Labeled* kerf type steel frame – minimum 16 gauge.
2. Edge Seals Required: 45 minutes – Pemko HSS 2000 - OR - any listed Hot Smoke Seal around Perimeter – OR - Pemko S88 around perimeter of door assembly – OR - 3M GIS/GIS+ applied either to door edge or to frame; 60 and 90 minute – Pemko HSS 2000 - OR - any listed Hot Smoke Seal around perimeter.
3. Trimming for height may be done only on the bottom rail (per NFPA 80, maximum trim of  $\frac{3}{4}$ " [19.0mm] allowed on site.
4. Surface-mounted hardware must be attached with through-bolts unless interior blocking is provided.
5. A maximum of 1/8" (3.2 mm) clearance between the frame and door (or leaves of pair) is allowed.
6. For Flush Bolts a strip of 1 inch wide Tecnofire 2000 or two strips of Pemko HSS2000 shall be applied across the top of the flush bolt.
7. Doors with light cutouts install a light kit listed and labeled for compliance with UBC 7-2-97 for specific type of door. Install kit per manufacturer's instructions.
8. If door assembly requires "S" rating for smoke rating, a *fire-rated* smoke and draft control gasket shall be installed to the opening. The smoke and draft control gasket shall be labeled showing compliance with UBC 7-2-97, Parts I & II. Smoke gaskets are to be installed per instructions provided with the gasket system and must be compatible with the door and frame type.



## INSTALLATION INSTRUCTIONS FOR 45, 60 & 90 MINUTE POSITIVE PRESSURE AND SMOKE CONTROL DOORS

---

To meet positive pressure and smoke control requirements per UBC 7-2-97, Parts I & II, doors must be installed with *fire-rated* smoke and draft control gasketing. In some cases, an intumescent seal may be required, as noted below. The smoke and draft control gasket shall be “Listed” for compliance with test procedure UBC Standard 7-2-97, Parts I & II. Refer to gasketing manufacturer’s installation instructions for frame preparation and application guidelines, unless otherwise specified below.

\*45, 60 or 90-minute positive pressure single swing doors – including door and transom assemblies with the use of a transom bar.

Install “Listed” smoke seal gasketing next to the stop and apply intumescent (HSS2000 -OR- any listed Hot Smoke Seal) 5/8” from the stop on both door jambs and header (see drawing B). For door and transom assemblies with a transom bar, use the same installation method for both the door and the transom. Install “Listed” smoke seal gasketing and intumescent on all edges of the frame around the transom.

\*45, 60 or 90-minute positive pressure pair with metal edge and astragal set:

Install “Listed” smoke seal gasketing next to the stop and apply intumescent (HSS2000 –OR- any listed Hot Smoke Seal) 5/8” from the stop on both door jambs and header, and on all edges of the frame around transom panels (see drawing B). After installing the metal edge and astragal on the doors, apply an additional strip of intumescent (HSS2000 Hot Smoke Seal) on one leaf of the pair at the meeting edge, 5/8” from the astragal (see drawing C).

\*45, 60 or 90-minute positive pressure pair without metal edges – including transom assemblies with a transom bar:

Install “Listed” smoke seal gasketing next to the stop end and apply intumescent (HSS2000 – OR- any listed Hot Smoke Seal) 5/8” from the stop on both door jambs and header (see drawing B). The meeting edge intumescent edge seal system is part of the door construction. Apply a strip of Pemko S77 smoke seal gasketing centered on top of the intumescent on one leaf of the pair at the meeting edge.  
(See drawing D).

Note: If Category A assembly is used, Refer to page 7, Paragraph 2.  
Frame applied intumescent in not required.



**Note:** Drawings on this page pertain to 45,60 & 90 minute rated doors.

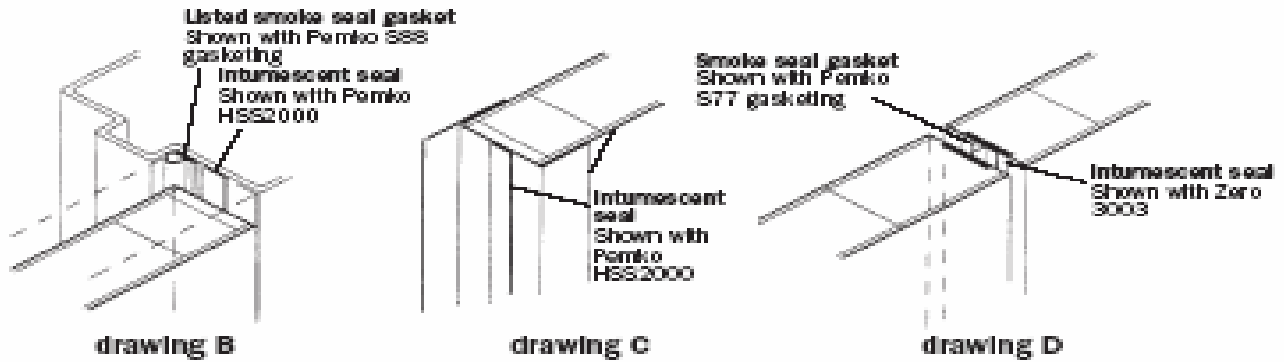

- Note 1: Any manufacturer's Hot Smoke seal that meets the requirements of UBC 7-2, Part I, Positive Pressure may be substituted for the products referenced within these installation instructions, providing that they are *Listed and Labeled* to meet the applicable size and requirements of the opening.
- Note 2: Any manufacturers smoke and draft control gasket that meets the requirements of UBC 7-2, Parts I & II, Positive Pressure may be substituted for the products referenced within these installation instructions, providing that they are *Listed and Labeled* to meet the applicable size and requirements of the opening.
- Note 3: All installation instructions are subject to change upon current technical reviews and testing procedures.